

Curaflex® Quick In A

NON-PRESSING WATER

- Sealing of penetrations
- Use in **on-site pipe sleeve** or **waterproof concrete core bore** (white tank)
- Hinged design, for **pipes that are already installed**



DOYMA
GRIP

DPS



25
years
guarantee

PRODUCT ADVANTAGES

- Easy assembly thanks to precise dimensions, large sealing areas
- Permanently sealed – no need to re-tension later (maintenance-free)
- Greater sealing performance of the gasket insert thanks to DPS and DOYMA-Grip
- Water-tight welded bolts
- With quick release (up to DN 500) for safe and secure closure
- For retrofitting around existing pipe
- Can be used for twin/element walls

TECHNICAL DETAILS

- Certified under FHRK test regulation GE 101 (no. G 30 322-2-1)
- Gas and water-tight
- Bending of medium pipes up to 8° is possible
- Can accommodate axial movements
- Single sealing
- Hinged design – available from DN 600 in split version with additional steel ring for stabilisation

THE GASKET INSERT CONSISTS OF:

- **Split frame rings:** asymmetrically profiled steel rings (DPS to KB/DN 350), with quick release (up to DN 500), GGV triple corrosion protection coating; optionally made of stainless steel 1.4301 (V2A) or 1.4571/1.4404 (V4A)
- **Split rubber seal with step cut:** elastomer, 27 mm thick EPDM seals (DOYMA-Grip), optional EPDM-TW, NBR (fuel/oil-resistant) or silicone (high temperature-resistant) or FPM (chemical-resistant)



ACCESSORIES (OPTIONAL)*

- Aquagard core bore sealant

* see corresponding section

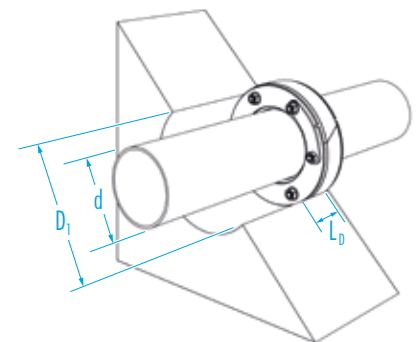

Curaflex® Quick In A

Inner diameter of pipe sleeve/core bore D _i [DN in mm]	Outer diameter of pipe/cable d [mm]	Article number
50 (49–53)	7 – 12	1 01 2 012 050 0 0
	13 – 18	1 01 2 015 050 0 0
	19 – 24	1 01 2 020 050 0 0
80 (79–83)	7 – 13	1 01 2 012 080 0 0
	14 – 21	1 01 2 020 080 0 0
	22 – 28	1 01 2 025 080 0 0
	29 – 35	1 01 2 032 080 0 0
	36 – 40	1 01 2 040 080 0 0
100 (99–104)	41 – 45	1 01 2 042 100 0 0
	46 – 52	1 01 2 050 100 0 0
	53 – 57	1 01 2 056 100 0 0
125 (124–128)	58 – 67	1 01 2 063 125 0 0
	68 – 77	1 01 2 075 125 0 0
150 (149–153)	78 – 85	1 01 2 078 150 0 0
	86 – 94	1 01 2 090 150 0 0
	95 – 104	1 01 2 098 150 0 0
200 (199–204)	105 – 115	1 01 2 110 200 0 0
	116 – 124	1 01 2 118 200 0 0
	125 – 135	1 01 2 125 200 0 0
	136 – 145	1 01 2 140 200 0 0
250 (247–253)	146 – 156	1 01 2 148 250 0 0
	157 – 165	1 01 2 160 250 0 0
	166 – 172	1 01 2 170 250 0 0
	173 – 179	1 01 2 175 250 0 0
	180 – 186	1 01 2 180 250 0 0
	187 – 190	1 01 2 190 250 0 0
	191 – 197	1 01 2 196 300 0 0
300 (297–304)	198 – 207	1 01 2 200 300 0 0
	208 – 215	1 01 2 210 300 0 0
	216 – 224	1 01 2 222 300 0 0
	225 – 233	1 01 2 225 300 0 0
350 (347–354)	234 – 240	1 01 2 240 350 0 0
	241 – 249	1 01 2 242 350 0 0
	250 – 259	1 01 2 250 350 0 0
	260 – 269	1 01 2 265 350 0 0
	270 – 278	1 01 2 273 350 0 0
	279 – 288	1 01 2 280 350 0 0
400 (397–404)	289 – 294	1 01 2 290 400 0 0
	295 – 300	1 01 2 296 400 0 0
	301 – 306	1 01 2 306 400 0 0
	307 – 311	1 01 2 310 400 0 0
	312 – 317	1 01 2 315 400 0 0
	318 – 322	1 01 2 320 400 0 0
	323 – 327	1 01 2 323 400 0 0
	328 – 333	1 01 2 328 400 0 0
	334 – 339	1 01 2 336 400 0 0
450 (447–454)	340 – 344	1 01 2 340 450 0 0
	345 – 350	1 01 2 350 450 0 0
	351 – 356	1 01 2 355 450 0 0
	357 – 362	1 01 2 362 450 0 0
	363 – 368	1 01 2 368 450 0 0
	369 – 370	1 01 2 370 450 0 0
	371 – 375	1 01 2 375 450 0 0
	376 – 380	1 01 2 380 450 0 0
500 (497–503)	381 – 386	1 01 2 386 500 0 0
	387 – 392	1 01 2 392 500 0 0
	393 – 397	1 01 2 397 500 0 0
	398 – 403	1 01 2 400 500 0 0
	404 – 409	1 01 2 406 500 0 0
	410 – 415	1 01 2 410 500 0 0
	416 – 420	1 01 2 420 500 0 0
	421 – 425	1 01 2 425 500 0 0
426 – 430	1 01 2 429 500 0 0	

L₀ (max. design length) [mm]: 60

Further material combinations and dimensions available upon request.