

Curaflex® 7006

 PRESSING WATER

- Flange plate with sleeve for penetrations
- Use **in front of the wall**
- For use with **tanking membranes** or **thick coating** (black tank)
- With **fixed and loose flange**
- Ideal for **renovations**

Dichtigkeitsprüf.
PB 5.1/17-206-1
MIPA Leipzig

25
years
guarantee



PRODUCT ADVANTAGES

- Sealing in front of the wall (condition of the bore/wall opening not relevant)
- Suitable for penetrations without a suitable core bore or pipe sleeve
- Optimally designed inner wall for holding the DOYMA sealing systems

TECHNICAL DETAILS

- With fixed and loose flange (loose flange split) made of steel in accordance with DIN 18195/DIN 18533
- For buildings with tanking membranes/thick coating (black tank)
- Gas and water-tight
- Depending on the tanking membrane, installed with Curaflex® packings (1775) arranged on both sides where there is thin and hard film, or accessories where there is a thick coating (1776): sanding of the contact surfaces of the fixed/loose flange

MATERIAL

- Steel, GGV triple corrosion protection coating; optionally made of stainless steel 1.4301 (V2A) or 1.4571/1.4404 (V4A)



ACCESSORIES (OPTIONAL)*

- Curaflex® packings (1775) for thin, hard films
- Accessories for thick coating
- Punch for thick coating

ABSOLUTELY NECESSARY WITH SPLIT VERSION!*

- Sealant, primer and adhesive cleaner

* see corresponding section



Variant:
Curaflex® 7006/T pipe sleeve –
split version, for installation with an
existing pipe.

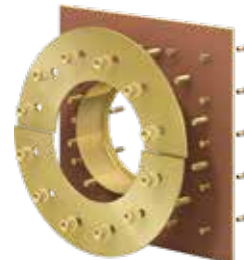

Variant:
Curaflex® 7006 pipe sleeve, sanded

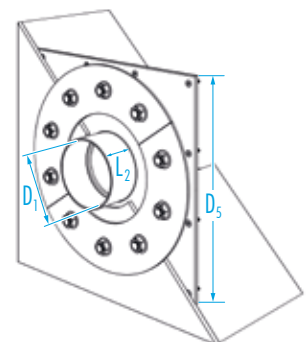

Curaflex® 7006

Inner diameter of pipe sleeve D ₁ [DN in mm]	Outer diameter/edge length of the fixed flange D ₃ max. [mm]	GGV	GGV/sanded for thick coating	Packings for thin or hard membranes
		Article number	Article number	Article number
80	440	1 70 6 080 000 0 0	1 70 6 080 000 5 0	1 99 6 775 080 7 0
100	460	1 70 6 100 000 0 0	1 70 6 100 000 5 0	1 99 6 775 100 7 0
125	480	1 70 6 125 000 0 0	1 70 6 125 000 5 0	1 99 6 775 125 7 0
150	510	1 70 6 150 000 0 0	1 70 6 150 000 5 0	1 99 6 775 150 7 0
200	560	1 70 6 200 000 0 0	1 70 6 200 000 5 0	1 99 6 775 200 7 0
250	610	1 70 6 250 000 0 0	1 70 6 250 000 5 0	1 99 6 775 250 7 0
300	660	1 70 6 300 000 0 0	1 70 6 300 000 5 0	1 99 6 775 300 7 0
350	710	1 70 6 350 000 0 0	1 70 6 350 000 5 0	1 99 6 775 350 7 0
400	760	1 70 6 400 000 0 0	1 70 6 400 000 5 0	1 99 6 775 400 7 0
450	810	1 70 6 450 000 0 0	1 70 6 450 000 5 0	1 99 6 775 450 7 0
500	860	1 70 6 500 000 0 0	1 70 6 500 000 5 0	1 99 6 775 500 7 0
600	960	—	—	—
700	1060	—	—	—

L2 (length of pipe socket) [mm]: 110

Further material combinations and dimensions available upon request.

Curaflex® 7006/T

Inner diameter of pipe sleeve D ₁ [DN in mm]	Outer diameter/edge length of the fixed flange D ₃ max. [mm]	GGV	GGV/sanded for thick coating	Packings for thin or hard membranes
		Article number	Article number	Article number
80	530	1 70 6 080 000 0 8	1 70 6 080 000 5 8	1 99 6 775 080 7 2
100	550	1 70 6 100 000 0 8	1 70 6 100 000 5 8	1 99 6 775 100 7 2
125	570	1 70 6 125 000 0 8	1 70 6 125 000 5 8	1 99 6 775 125 7 2
150	600	1 70 6 150 000 0 8	1 70 6 150 000 5 8	1 99 6 775 150 7 2
200	650	1 70 6 200 000 0 8	1 70 6 200 000 5 8	1 99 6 775 200 7 2
250	700	1 70 6 250 000 0 8	1 70 6 250 000 5 8	1 99 6 775 250 7 2
300	750	1 70 6 300 000 0 8	1 70 6 300 000 5 8	1 99 6 775 300 7 2
350	800	1 70 6 350 000 0 8	1 70 6 350 000 5 8	1 99 6 775 350 7 2
400	850	1 70 6 400 000 0 8	1 70 6 400 000 5 8	1 99 6 775 400 7 2
450	900	1 70 6 450 000 0 8	1 70 6 450 000 5 8	1 99 6 775 450 7 2
500	950	1 70 6 500 000 0 8	1 70 6 500 000 5 8	1 99 6 775 500 7 2
600	1050	—	—	—
700	1150	—	—	—

L2 (length of pipe socket) [mm]: 110

Further material combinations and dimensions available upon request.