

INSTALLATION INSTRUCTIONS

HKD Connection funnel



HKD Connection funnel

Intended purpose

Connection funnel with integrated impact-protection insert for concreting in the floor slab. Suitable for waterproof floor slabs (white tank), e.g. waterproof concrete with pressing or non-pressing water. The connection funnel is used to hold a KG pipe (not included in scope of delivery).

Please note

The processing notes for installing the connection funnel can be found on the following page.

Scope of delivery

- Connection funnel
- Impact-protection insert
- Tightening strap

Installation steps

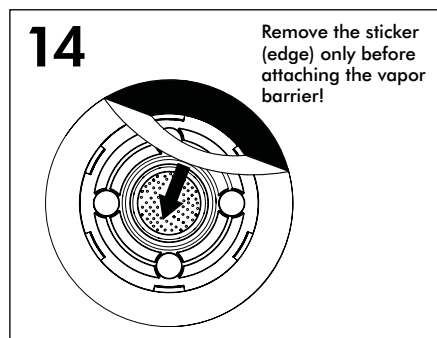
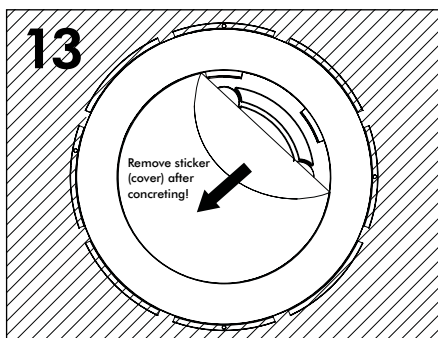
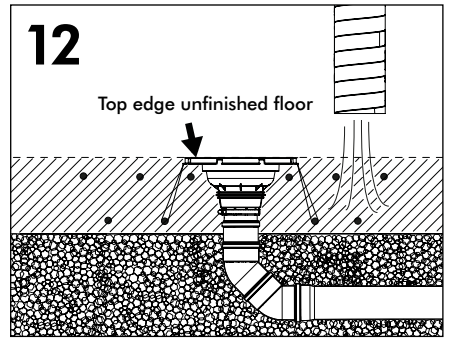
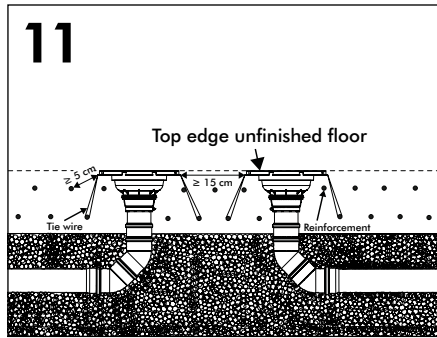
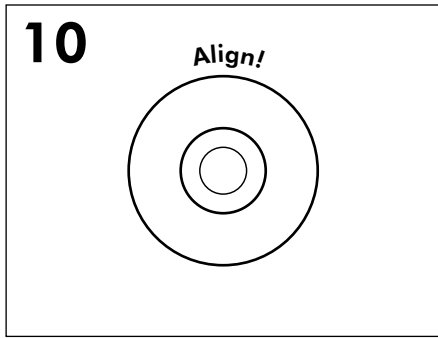
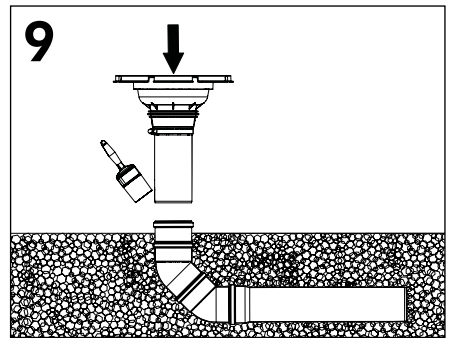
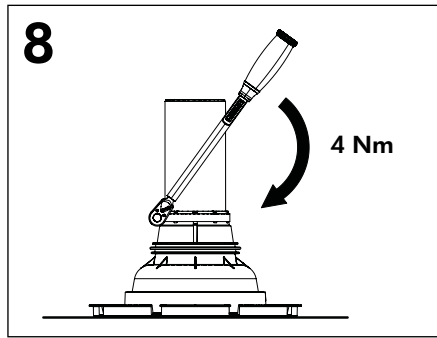
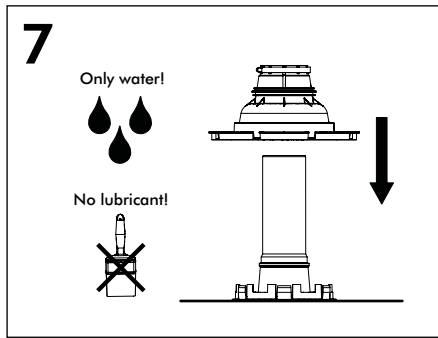
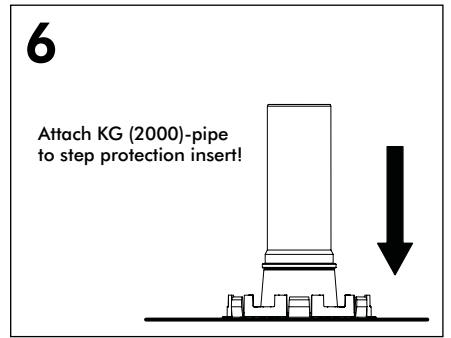
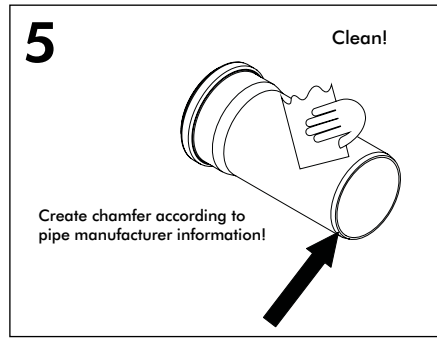
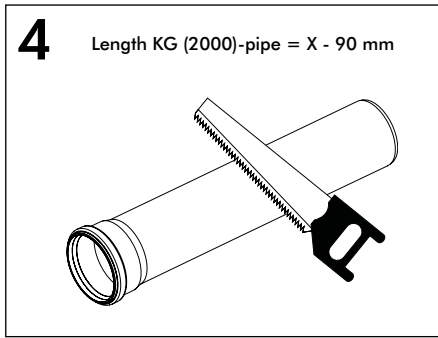
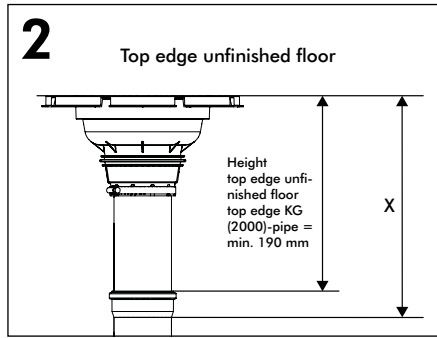
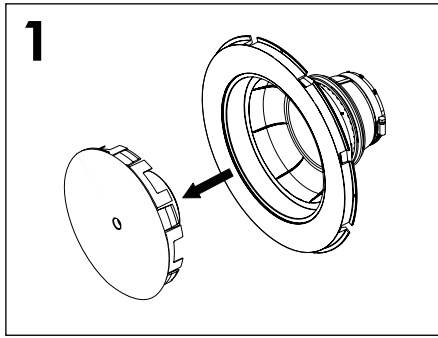



Waterproof



Safe to step on



Radonproof

DOYMA products are continuously being further developed. Technical changes will be made without prior notice.
More information at www.doyma.de

DOYMA GmbH & Co

SEALING SYSTEMS

FIRE PROTECTION SYSTEMS

Industriestr. 43-57
28876 Oyten

Phone: 0 42 07/91 66-300
Fax: 0 42 07/91 66-199

www.doyma.de
info@doyma.de